

10-610-10

DWG. NO.

REVISIONS				
ZONE	REV.	DESCRIPTION	DATE	APPROVED
	PR1	PRE-RELEASE 1	06/10/08	

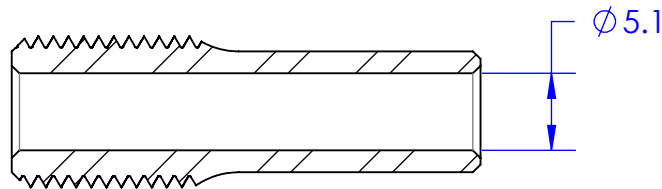
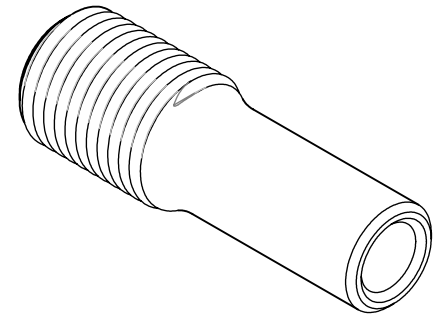
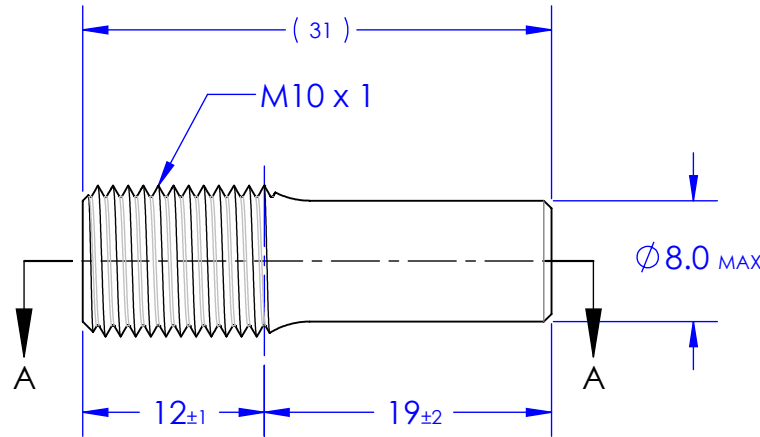
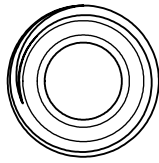

SECTION A-A

NOTE: DEBUR EDGES C0.5 MAX

**PROPRIETARY AND CONFIDENTIAL**  
 THE INFORMATION CONTAINED IN THIS DRAWING IS THE SOLE PROPERTY OF STAINLESS CABLE & RAILING, INC. ANY REPRODUCTION IN PART OR AS A WHOLE WITHOUT THE WRITTEN PERMISSION OF STAINLESS CABLE & RAILING, INC. IS PROHIBITED.

		UNLESS OTHERWISE SPECIFIED: DIMENSIONS ARE IN Millimeters	NAME	DATE	Stainless Cable & Railing, Inc. 888-686-7245 (RAIL)
		TOLERANCES: x = 0.5 x.x = 0.1 x.xx = 0.01 x.xxx = 0.005	DRAWN	GM	
		INTERPRET GEOMETRIC TOLERANCING PER:	CHECKED		TITLE:
		MATERIAL 316 Stainless	ENG APPR.		Swage Stud
		FINISH	MFG APPR.		
NEXT ASSY	USED ON		Q.A.		SIZE
			COMMENTS:		DWG. NO.
					<b>A</b> 01-019-01
					REV
					PR1
APPLICATION		DO NOT SCALE DRAWING			SCALE: 2:1
					WEIGHT:
					SHEET 1 OF 1