

10-900-70

DWG. NO.

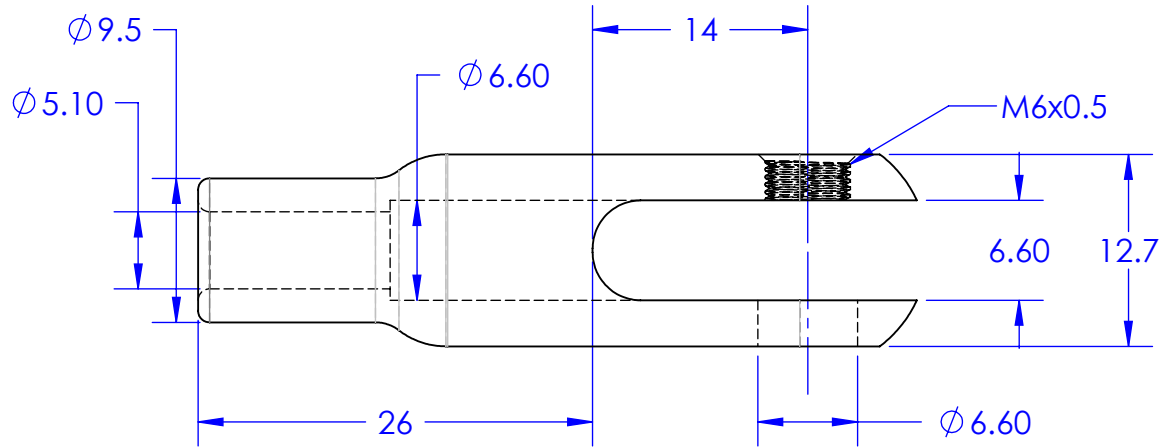
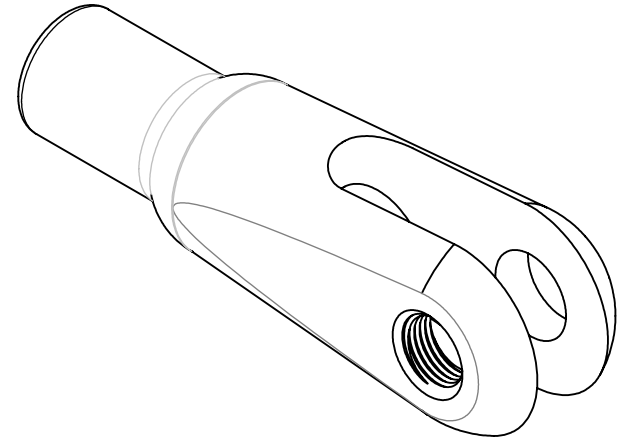
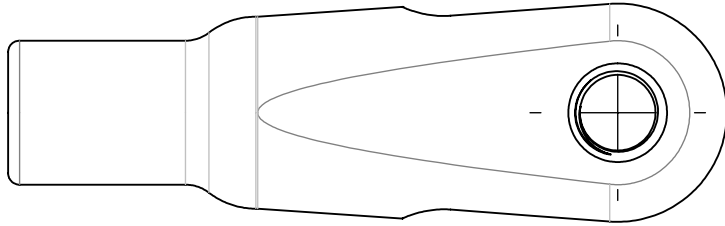

PROPRIETARY AND CONFIDENTIAL
 THE INFORMATION CONTAINED IN THIS DRAWING IS THE SOLE PROPERTY OF STAINLESS CABLE & RAILING, INC. ANY REPRODUCTION IN PART OR AS A WHOLE WITHOUT THE WRITTEN PERMISSION OF STAINLESS CABLE & RAILING, INC. IS PROHIBITED.

		UNLESS OTHERWISE SPECIFIED: DIMENSIONS ARE IN Millimeters	NAME	DATE
		TOLERANCES: x = 0.1 x.x = 0.1 x.xx = 0.01 x.xxx = 0.005	DRAWN	GM 03/19/08
		INTERPRET GEOMETRIC TOLERANCING PER:	CHECKED	
		MATERIAL 316 Stainless	ENG APPR.	
		FINISH	MFG APPR.	
			Q.A.	
			COMMENTS:	
NEXT ASSY	USED ON			
APPLICATION		DO NOT SCALE DRAWING		

Stainless Cable & Railing, Inc. 888-686-7245 (RAIL)		
TITLE: Fixed Jaw Clevis		
SIZE A	DWG. NO. 02-006-01	REV PR1
SCALE: 2:1	WEIGHT:	SHEET 1 OF 1

5

4

3

2

1