

10-800-10

DWG. NO.

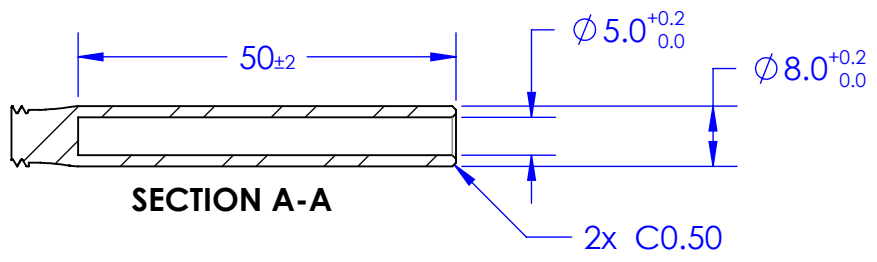
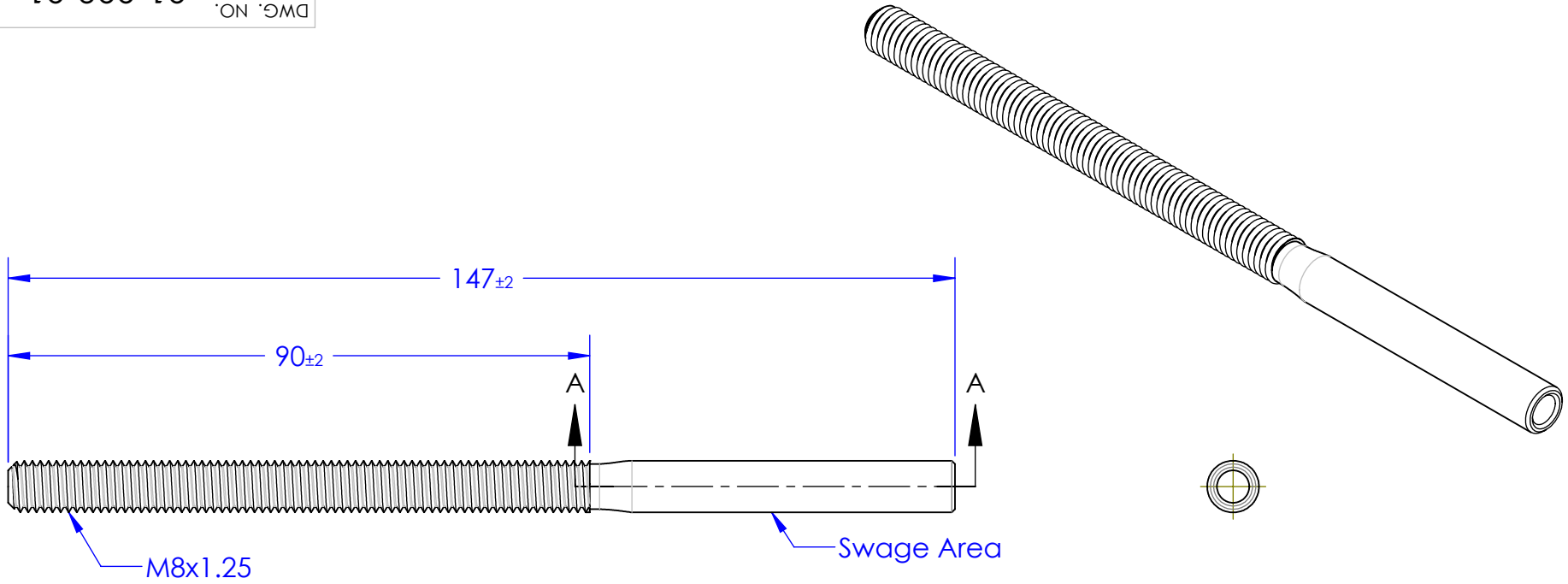

PROPRIETARY AND CONFIDENTIAL
 THE INFORMATION CONTAINED IN THIS DRAWING IS THE SOLE PROPERTY OF **STAINLESS CABLE & RAILING, INC.** ANY REPRODUCTION IN PART OR AS A WHOLE WITHOUT THE WRITTEN PERMISSION OF **STAINLESS CABLE & RAILING, INC.** IS PROHIBITED.

		UNLESS OTHERWISE SPECIFIED: DIMENSIONS ARE IN Millimeters		NAME	DATE
		TOLERANCES: x = 0.5 x.x = 0.1 x.xx = 0.01 x.xxx = 0.005	DRAWN	GM	03/16/08
		INTERPRET GEOMETRIC TOLERANCING PER:	CHECKED		
		MATERIAL 316 Stainless	ENG APPR.		
		FINISH	MFG APPR.		
			Q.A.		
			COMMENTS:		
NEXT ASSY	USED ON				
APPLICATION		DO NOT SCALE DRAWING			

Stainless Cable & Railing, Inc. 888-686-7245 (RAIL)		
TITLE: Field Tensioner		
SIZE A	DWG. NO. 01-008-01	REV PR2
SCALE: 1:1	WEIGHT:	SHEET 1 OF 1