

10-270-10

DWG. NO.

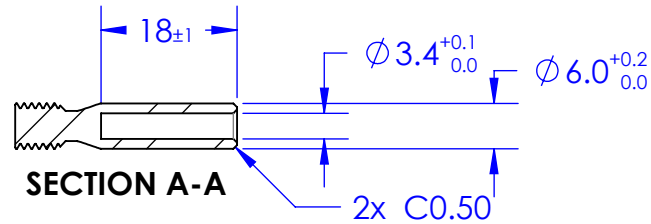
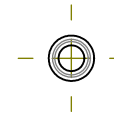
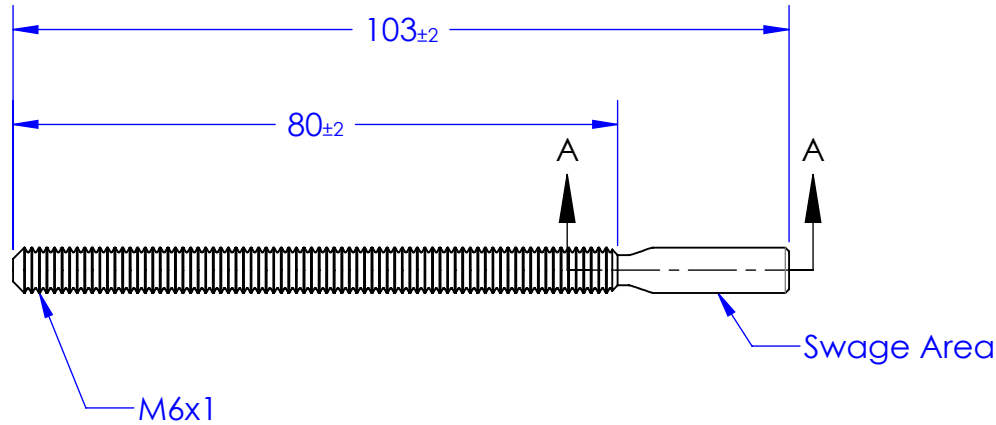
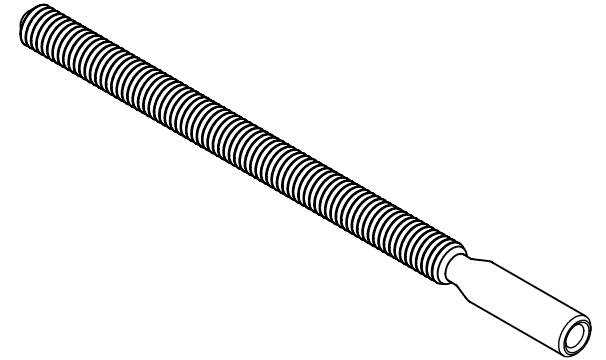

PROPRIETARY AND CONFIDENTIAL
 THE INFORMATION CONTAINED IN THIS DRAWING IS THE SOLE PROPERTY OF **STAINLESS CABLE & RAILING, INC.** ANY REPRODUCTION IN PART OR AS A WHOLE WITHOUT THE WRITTEN PERMISSION OF **STAINLESS CABLE & RAILING, INC.** IS PROHIBITED.

		UNLESS OTHERWISE SPECIFIED: DIMENSIONS ARE IN Millimeters	NAME	DATE
			DRAWN	GM
		TOLERANCES: x = 0.5 x.x = 0.1 x.xx = 0.01 x.xxx = 0.005	CHECKED	
			ENG APPR.	
			MFG APPR.	
		INTERPRET GEOMETRIC TOLERANCING PER:	Q.A.	
		MATERIAL	COMMENTS:	
		316 Stainless		
NEXT ASSY	USED ON	FINISH		
APPLICATION		DO NOT SCALE DRAWING		

Stainless Cable & Railing, Inc. 888-686-7245 (RAIL)		
TITLE: Factory Tensioner		
SIZE	DWG. NO.	REV
A	01-027-01	PR2
SCALE: 1:1	WEIGHT:	SHEET 1 OF 1

5

4

3

2

1